



www.tuffstufffitness.com



CG-9515 INNER/OUTER THIGH

- Unique dual design allows for adduction and abduction exercises.
- Swivel thigh pads allow quick exercise set up.
- Multiple start positions for both inner and outer thigh exercises.
- Built-in handles for support.

- Heavy duty 2" x 4" 11-gauge oval steel frames combined with 2" 11-gauge round tubing accents.
- Sealed 2" roller bearings and 1" diameter solid steel axle encased in machined housing on all primary pivot points.
- 4-1/2" and 3-1/2" diameter fiberglass reinforced nylon pulleys with sealed bearings enclosed in protective steel covers.
- High density EMR Urethane foam padding with double-stitched upholstery (black) secured to 3/4" plywood backing.
- Electrostatically applied powder coat finish baked at 400°F.
- 3/16" USA-Made/Certified EXERFLEX PRO® high performance fitness cable.
- Magnetically secured selector pins and steel weight stacks are easily accessible from seated position.
- 3/4" precision ground, hard chrome finish, solid steel guide rods.
- Steel weight stack enclosures with decorative built-in storage compartment cover.
- Thermoplastic rubber handgrips secured with aluminum end caps for durability and improved feel.
- Protective rubber stabilizer feet with anchoring holes.
- Custom two tone finish (standard):

- (1) Platinum Sparkle – main frame
- (2) Charcoal Texture – accent

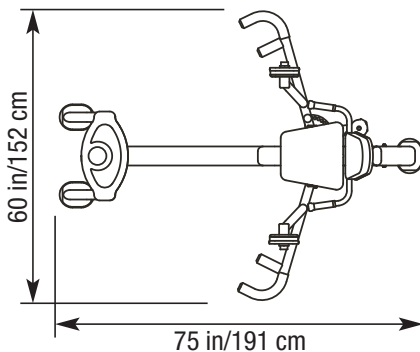

Height: 59 in/150 cm Weight: 415 lb/188 kg
150 lbs. steel weight stack

CUSTOMIZATION

Finish, upholstery and embroidered wear covers (personalized brand logo) are also available to further enhance your company name. Also available is our factory assembly of the CalGym equipment – call for pricing & availability from your sales representative.

COMMERCIAL WARRANTY*

- 10 YEARS:** Structural main frames, welds, cams and weight plates.
- 5 YEARS:** Pivot bearings, pulleys, bushings, and guide rods.
- 1 YEAR:** Pull-pin components and rail wheels.
- 6 MONTHS:** Upholstery, cables, finish, and rubber grips.

ALL OTHER PARTS not mentioned, one year from the date of delivery to the original purchaser.

* Not recommended for membership based or dues paying facilities – call your sales representative for details.

CALGYM